



Cooling system components, removing and installing

Warning!

When doing any repair work, especially in the engine compartment, pay attention to the following due to clearance issues:

- **Route all the various lines (e.g. for fuel, hydraulics, EVAP system, coolant, refrigerant, brake fluid and vacuum lines and hoses) and electrical wiring so that the original positions are restored.**
- **Ensure sufficient clearance to all moving or hot components.**

Note:

- *When the engine is warm the cooling system is under pressure. If necessary release pressure before beginning repair work.*
- *Hoses are secured with spring-type clips. In cases of repair only use spring-type clips.*

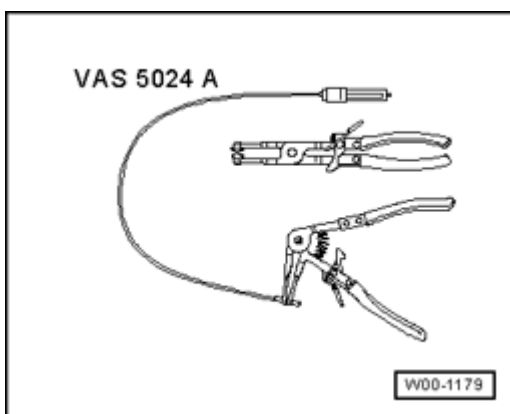

- *The spring-type clip pliers VAS 5024A are recommended for installing spring-type clips.*
- *When installing coolant hoses, make sure they are free of stress and do not come into contact with other components (observe markings on coolant connections and hoses).*

Perform leak test of cooling system using cooling system tester V.A.G 1274 , adapter V.A.G 1274/8 and adapter V.A.G 1274/9 .

Cooling system components, body side ⇒ [19-1, Cooling system components, body side](#) .

Cooling system components, engine side ⇒ [19-1, Cooling system components, engine side](#) .

Draining and filling with coolant ⇒ [19-1, Cooling system, draining and filling](#) .

Coolant mixture ratios ⇒ [19-1, Cooling system, draining and filling](#) , Coolant, draining and filling.

Cooling system components, body side

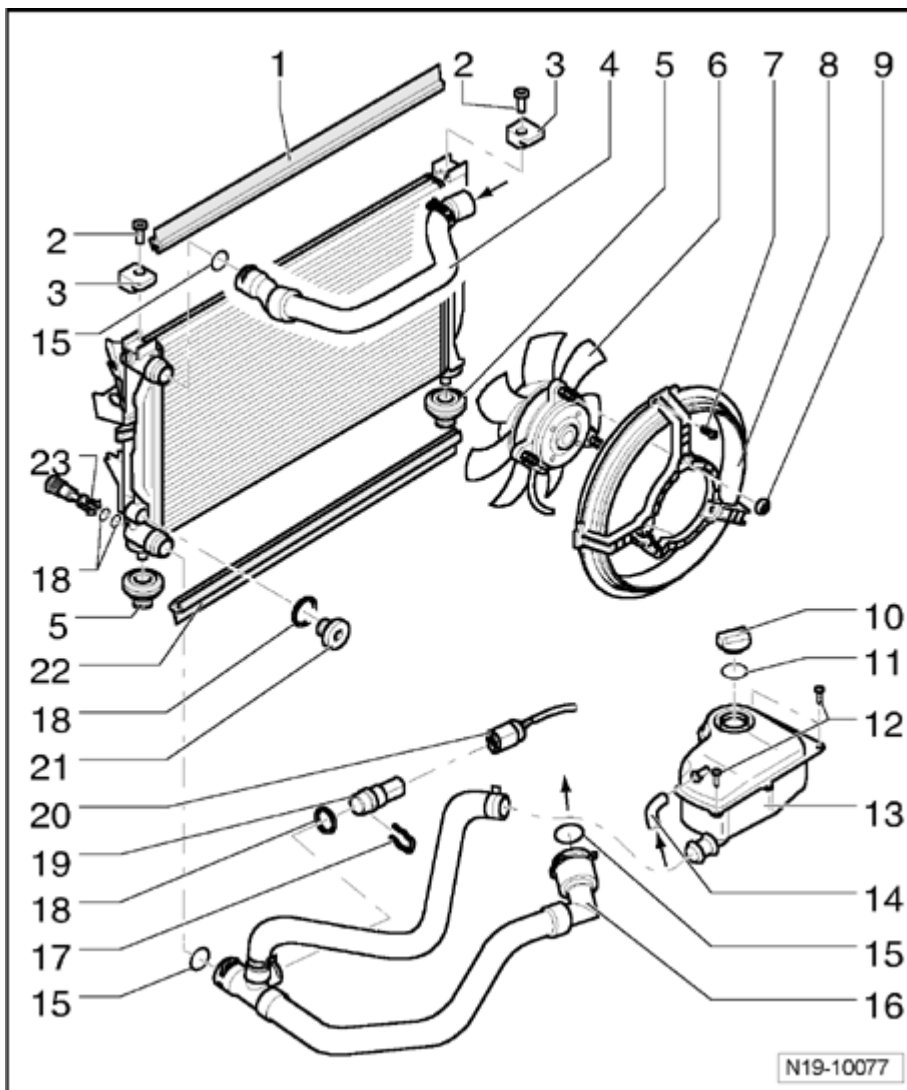

■ Sealing lip

- For upper radiator

- **Securing pin**
- **Securing rubber**
- **Upper coolant hose**
 - From upper coolant pipe ⇒ [Item - 2 -](#)
 - Secured to radiator with a retaining clip
 - Ensure seated tightly

- **Rubber washer**
- **Coolant Fan V7**
- **Bolt**
- **Fan ring**
 - Is clipped into intake air elbow and secured with bolt

- **10 Nm**
- **Cap**
 - Check using cooling system tester V.A.G 1274 and adapter V.A.G 1274/9
 - Test pressure: 1.4...1.6 bar

- **O-ring**
 - Replace if damaged

- **3 Nm**
- **Reservoir**
 - Perform leak test of cooling system using cooling system tester V.A.G 1274 and adapter V.A.G 1274/8

- **Coolant hose**
 - From upper coolant pipe ⇒

[Item - 2 -](#)

- **O-ring**
 - Check for secure seat
 - Replace if damaged

- **Lower coolant hose**
 - To housing for coolant thermostat ⇒ [Item - 17 -](#)
 - Secured to radiator and thermostat housing with a retaining clip
 - Ensure seated tightly

- **Retaining clip**
 - Check for secure seat

- **O-ring**
 - Replace if damaged

- **Coolant Fan Control (FC) Thermal Switch F18**
 - For electric fan
 - Only vehicles with optional equipment
 - Switch temperatures: 1. Speed on: 92 to 97 ° C, off: 84 to 91 ° C; 2. Speed on: 99 to 105 ° C, off: 91 to 98 ° C

- **Connector**
 - For Coolant Fan Control (FC) thermal switch

- **Locking bolt, 10 Nm**

- **Sealing lip**
 - For bottom of radiator

- **Drain plug**

- Cooling system, draining and filling ⇒ [19-1, Cooling system, draining and filling](#)

Cooling system components, engine side

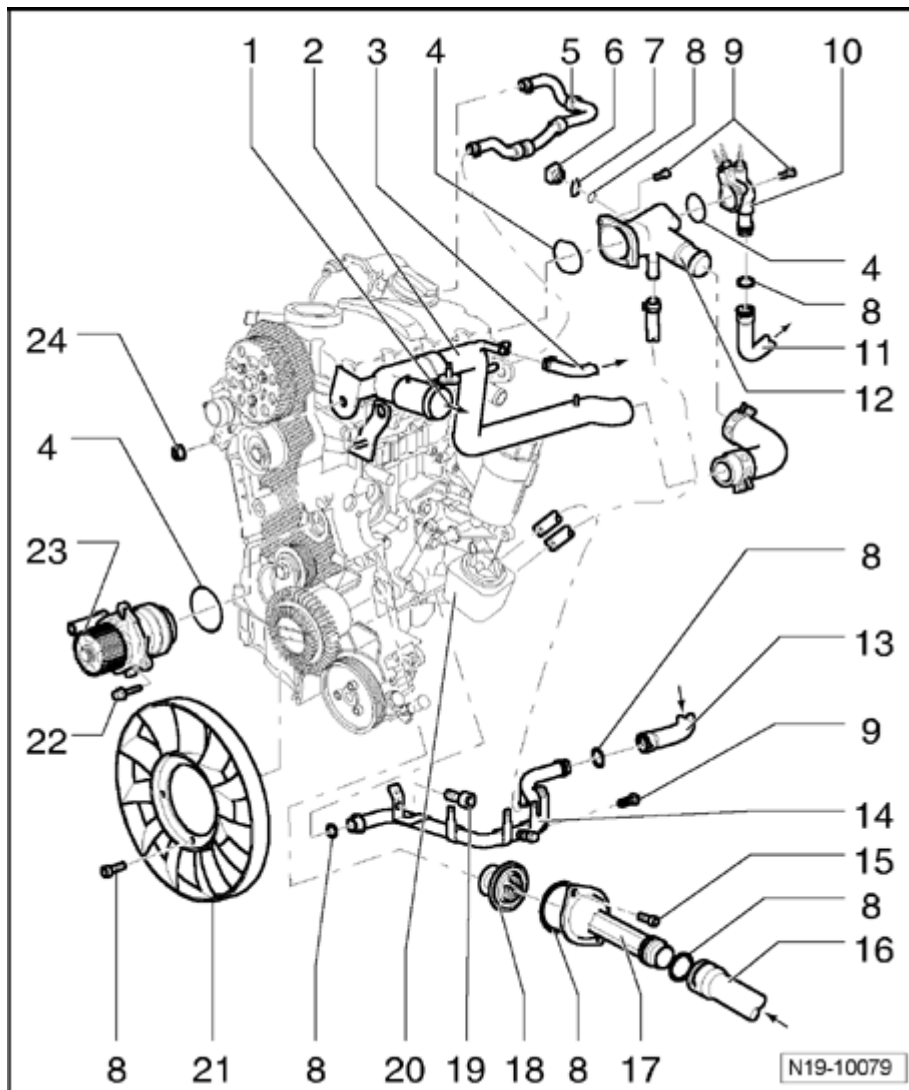

- **To upper radiator**

- ⇒ [Item - 4 -](#)

- **Upper coolant line**

- **Coolant hose**

- To upper coolant reservoir ⇒ [Item - 14 -](#)

- **O-ring**
 - Check for secure seat
 - Replace

- **Coolant hose**
- **Engine Coolant Temperature (ECT) Sensor G62**
 - With Engine Coolant Temperature (ECT) Gauge Sensor G2

- **Retaining clip**
 - Check for secure seat

- **O-ring**
 - Replace

- **10 Nm**
- **Connecting piece**
 - Only vehicles with optional equipment
 - With glow plugs for coolant

- **Coolant hose**
 - To heat exchanger
 - Secured to connections with retaining clip
 - Ensure seated tightly

- **Connecting piece**
- **Coolant hose**
 - From heat exchanger
 - Secured to lower coolant pipe with retaining clip
 - Ensure seated tightly

- **Lower coolant line**
- **15 Nm**
- **Coolant hose**
 - From lower radiator ⇒ [Item - 16 -](#)
 - Secured to radiator and thermostat housing with a retaining clip
 - Ensure seated tightly
- **Connecting piece**
 - For thermostat
- **Coolant thermostat**
 - Removing and installing ⇒ [19-1, Coolant thermostat, removing and installing](#)
 - Observe installed location ⇒ [19-1, Coolant thermostat, removing and installing](#) , Coolant thermostat, removing and installing
 - Checking: Heat up thermostat in water
 - Opening begins: approx. 85 ° C
 - Ends: approx. 105 ° C
 - Opening lift: min. 7 mm
- **40 Nm**
- **Oil cooler**
- **Fan wheel**
 - For viscous fan clutch
 - Viscous fan clutch, removing and installing ⇒ [19-1, Viscous fan clutch, removing and installing](#)

- 15 Nm
- Coolant pump
 - Check for ease of movement
 - Note installation position
 - Removing and installing ⇒ [19-1, Coolant pump, removing and installing](#)
- 25 Nm

Cooling system, draining and filling

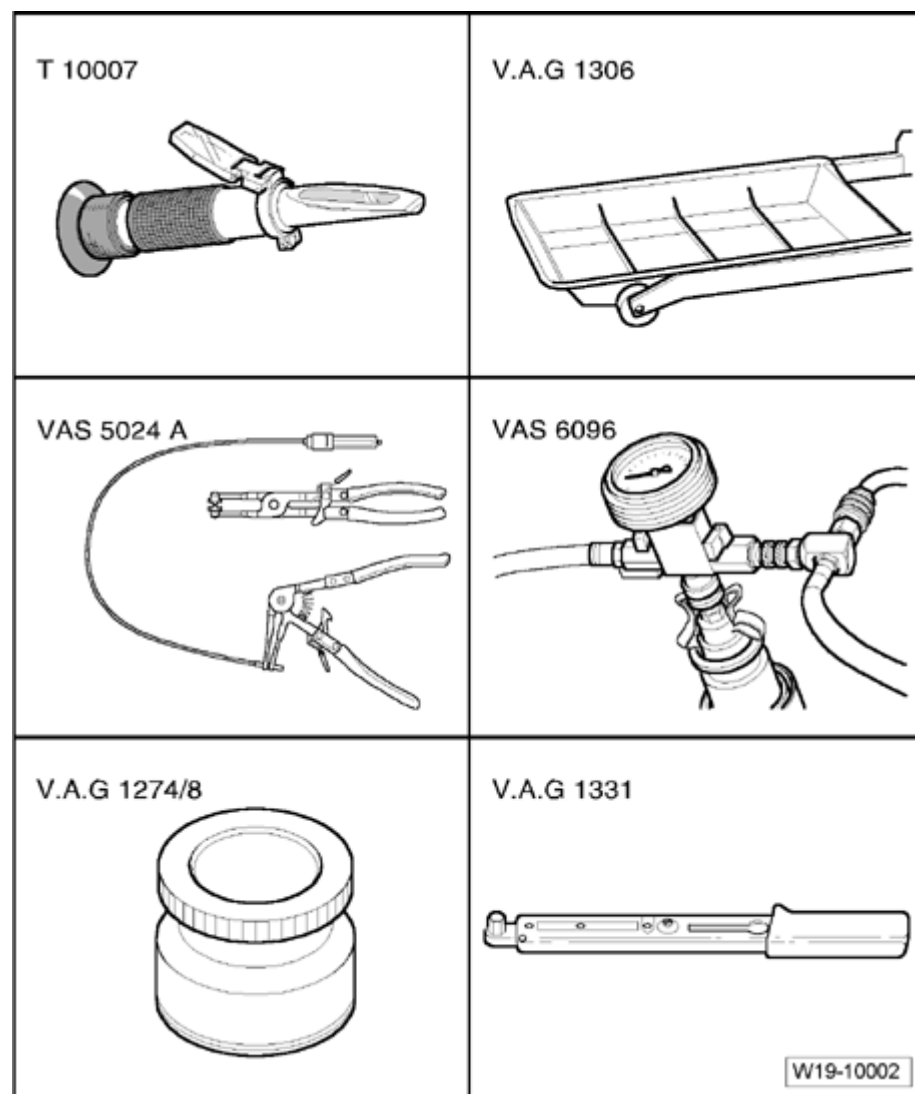

Special tools, testers and auxiliary items required

- Refractometer T10007

- Drip tray V.A.G 1306
- Spring-type clip pliers VAS 5024A
- Cooling system charge unit VAS 6096
- Adapter V.A.G 1274/8
- Torque wrench (5 to 50 Nm) V.A.G 1331

Special tools, testers and auxiliary items required

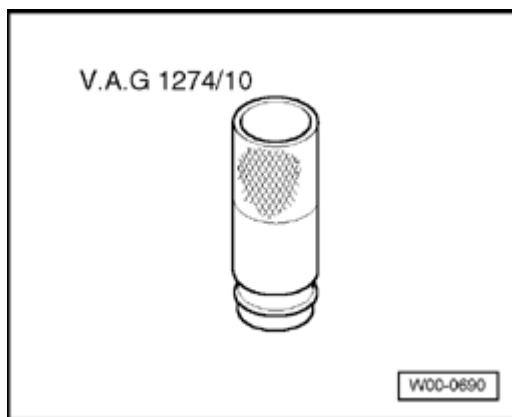

- Adapter V.A.G 1274/10

Draining

Caution!

When opening the expansion tank, hot steam may be released. Cover the cap with a rag and open very carefully.

- Open cap on coolant expansion tank.
- Remove sound insulation pan:

⇒ [Repair Manual, Body Exterior, Repair Group 50, Sound insulation](#)

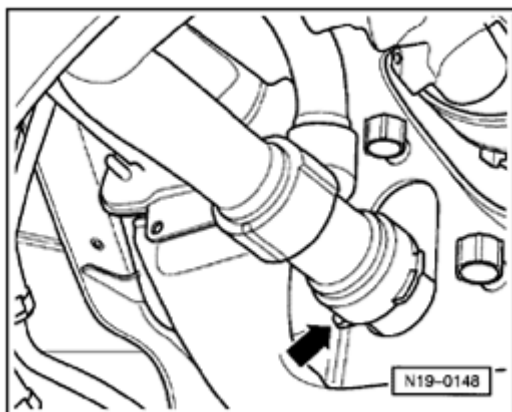

- Pull coolant hose retaining clip - **arrow** - off downward and remove coolant hose from radiator.

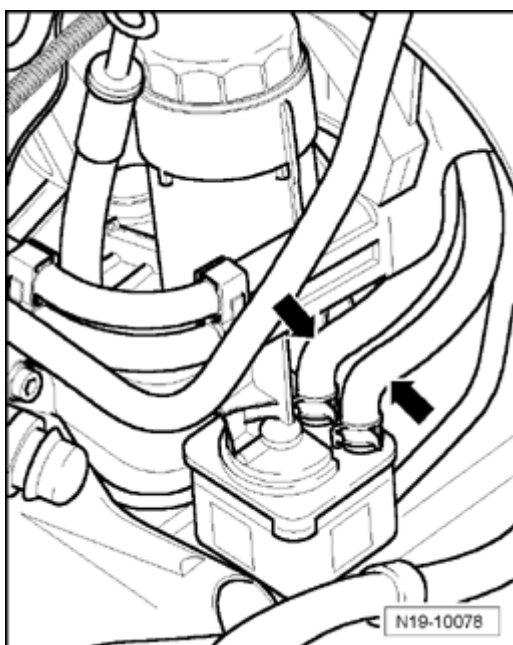

- In addition, drain coolant from engine by disconnecting coolant hoses at oil cooler - **arrows** - .

Note:

- *Observe disposal regulations for coolant!*

Filling

Note:

- *Only use coolant additive G 12 according to TL "VW 774 F" . Distinguishing color: violet*
- *G 12 violet according to TL "VW 774 F" may be mixed with previous coolant additive G 12 red!*

- *"G 12" and coolant additives marked in accordance with TL "VW 774 F" prevent frost and corrosion damage, scaling and also raise the boiling point of the coolant. For this reason the system must be filled all year round with frost and corrosion protection additives.*
- *Because of its high boiling point, the coolant improves engine reliability under heavy loads, particularly in countries with tropical climates.*
- *Protection against frost must be assured to about -25 ° C (in arctic climatic countries to about -35 ° C).*
- *The coolant concentration must not be reduced by adding water even in warmer seasons and in warmer countries. The coolant additive portion must be at least 40%.*
- *If for climatic reasons a greater frost protection is required, the amount of G 12 can be increased, but only up to 60% (frost protection to about -40 ° C), as otherwise frost protection is reduced again and cooling effectiveness is also reduced.*
- *Use only clean drinking water for mixing.*
- *If radiator, heat exchanger, cylinder head or cylinder head gasket is replaced, do not reuse old coolant.*

Recommended mixture ratios:

Frost protection to	Anti-freeze portion	G 12 ¹⁾	Water ¹⁾
-25 ° C	40%	3.0 L	4.0 L
-35 ° C	50%	3.5 L	3.5 L

1) The quantity of coolant can vary depending upon the vehicle equipment.

- Install lower coolant hose and secure.
- Connect coolant hoses on oil cooler.

With cooling system charge unit VAS 6096 :

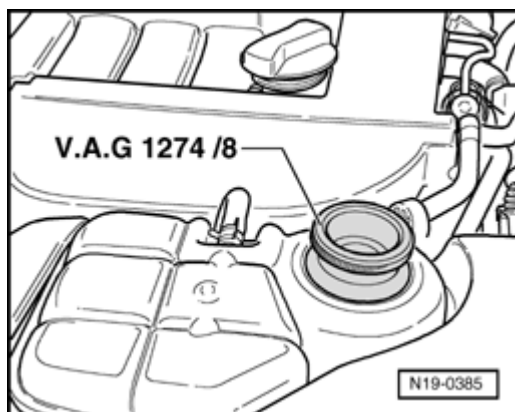

- Screw adapter V.A.G 1274/8 onto expansion tank.
- Fill coolant circuit using cooling system charge unit VAS 6096 . ⇒ *Operating instructions for cooling system charge unit VAS 6096*

Without cooling system charge unit VAS 6096 :

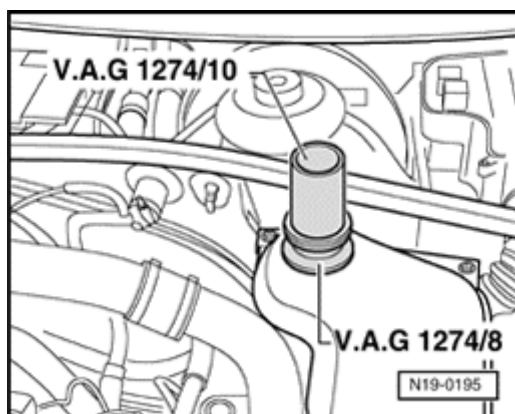

- Screw adapter V.A.G 1274/8 on expansion tank and extend it using adapter for V.A.G 1274 tester V.A.G 1274/10 .

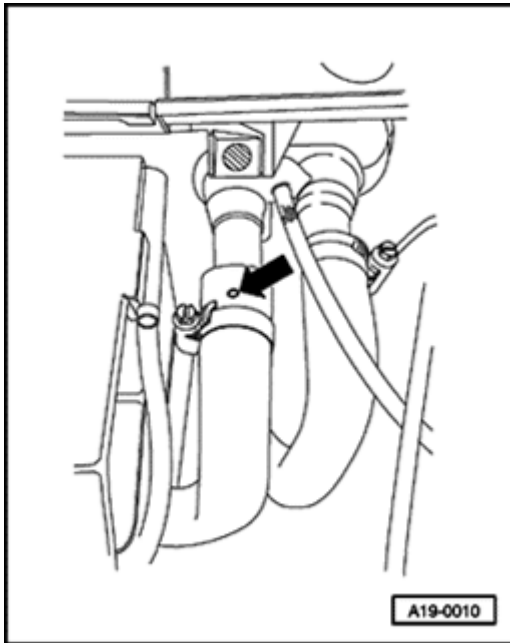

- Loosen coolant hose on heater core and pull back hose sufficiently so that bleeder hole in coolant hose - **arrow** - is no longer covered by connecting piece.
- Fill with coolant until it escapes from coolant hose bleeder hole.
- Push coolant hose on connection and secure it.

With and without cooling system charge unit VAS 6096 :

- Close expansion tank.
- Turn off heater controls.
- Start engine and maintain an engine speed of about 2000 rpm for approx. 3 minutes.
- Allow engine to run at idle speed until lower hose on radiator becomes hot.

Caution!

When opening the expansion tank, hot steam may be released. Cover the cap with a rag and open very carefully.

- Check coolant level and top off if necessary. With engine at operating temperature, coolant level must be at max. marking. With engine cold, coolant level must be between min. and max. marking.

Radiator, removing and installing

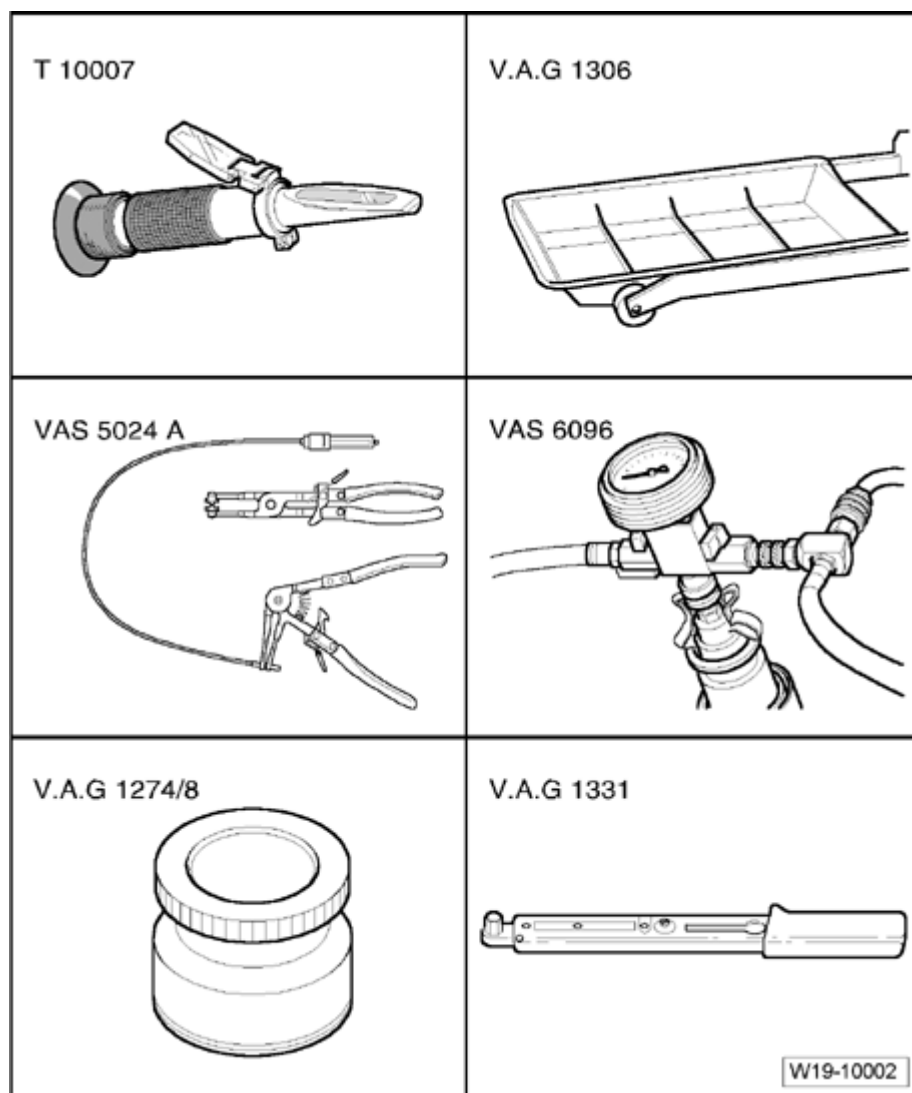

Special tools, testers and auxiliary items required

- Refractometer T10007
- Drip tray V.A.G 1306
- Pliers for spring type clips VAS 5024 A
- Cooling system charge unit VAS 6096
- Adapter V.A.G 1274/8
- Torque wrench (5 to 50 Nm) V.A.G 1331

Special tools, testers and auxiliary items required

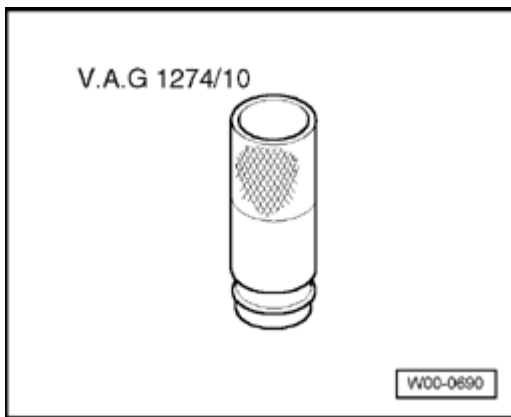

- Adapter V.A.G 1274/10

Removing

- Drain coolant ⇒ [19-1, Cooling system, draining and filling](#) .

- Remove front bumper:

⇒ [Repair Manual, Body Exterior, Repair Group 63, Assembly overview - front bumper](#)

- Pull off coolant hoses from radiator.

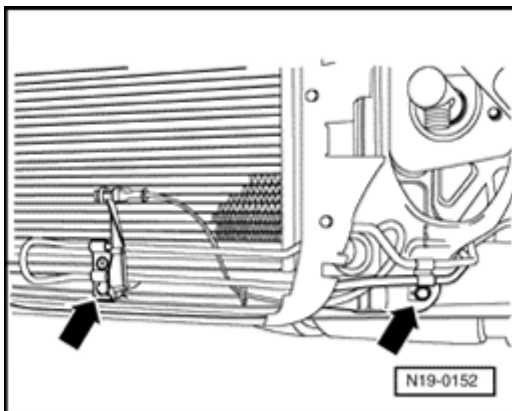

- Unbolt cooling coil for power steering fluid (arrows) and let hang free; Do not open hydraulic fluid circuit.

- Remove upper radiator securing clips and remove radiator toward front.

Vehicles with air conditioning

- Observe additional information and removal work ⇒ [19-1, Additional information and assembly work on vehicles with](#)

[air conditioning](#) .

Installing

Installation is performed in the reverse order of removal, noting the following:

- Fill with coolant ⇒ [19-1, Cooling system, draining and filling](#) .

- Check electrical connections and routing:

⇒ *Repair Manual, Electrical Equipment, Repair Group 97,*

- Install front bumper

⇒ [Repair Manual, Body Exterior, Repair Group 63, Assembly overview - front bumper](#)

Additional information and assembly work on vehicles with air conditioning

Warning!

The air conditioning refrigerant circuit must not be opened.

Note:

- *Do not bend or stretch lines or hoses as condenser and/or refrigerant lines/hoses may be damaged.*

- Remove retaining clamp(s) from refrigerant lines.

- Unscrew condenser from radiator and pull forward as far as possible.

- Secure condenser to body so that refrigerant lines/hoses are not stressed.

- Pull radiator out between condenser and lock carrier.

Coolant pump, removing and installing

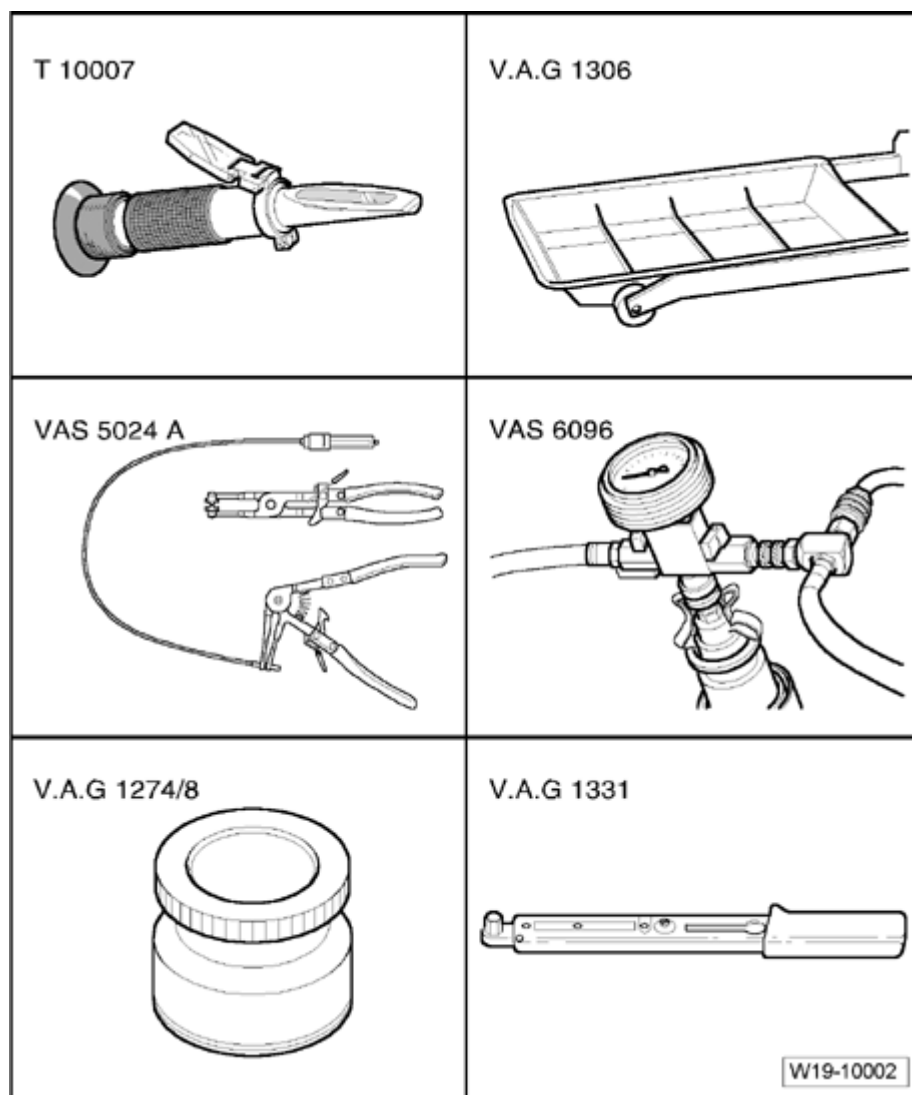

Special tools, testers and auxiliary items required

- Refractometer T10007
- Drip tray V.A.G 1306
- Pliers for spring type clips VAS 5024 A
- Cooling system charge unit VAS 6096
- Adapter V.A.G 1274/8
- Torque wrench (5 to 50 Nm) V.A.G 1331

Special tools, testers and auxiliary items required

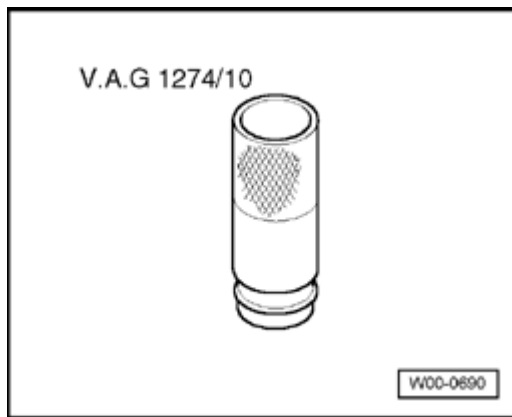

- Adapter V.A.G 1274/10

Removing

Note:

- *Always replace gaskets and seals.*

- Bring lock carrier into service position.

⇒ *Repair Manual, Body Exterior, Repair Group 50, Body - front*

- Drain coolant ⇒ [19-1, Cooling system, draining and filling](#) .

- Remove ribbed belt ⇒ [13-1, Ribbed belt, removing and installing](#)

- Remove toothed belt ⇒ [15-1, Toothed belt, removing, installing and tensioning](#) .

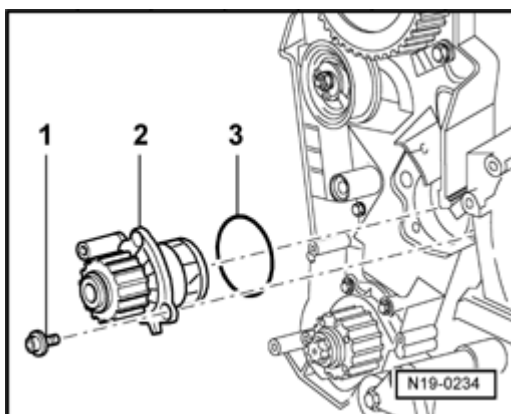

- Remove bolts - **1** - of coolant pump - **2** - and carefully take

out coolant pump.

Installing

Installation is performed in the reverse order of removal, note the following:

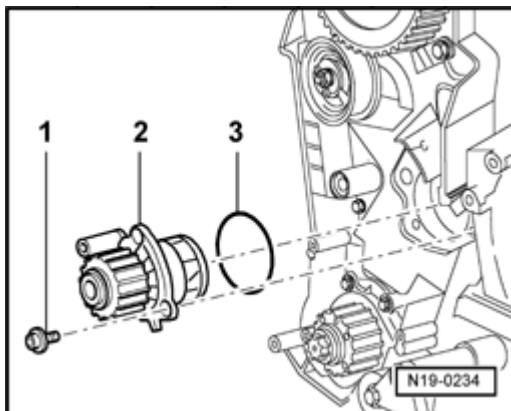

- Soak new O-ring - **3** - with coolant and install.

- Place coolant pump - **2** - into cylinder block and fasten bolts - **1** - to 15 Nm.

Note:

- *The sealing plug of the coolant pump faces downward.*

- Install toothed belt ⇒ [15-1, Toothed belt, removing, installing and tensioning](#) .

- Install ribbed belt ⇒ [13-1, Ribbed belt, removing and installing](#) .

- Refill with coolant ⇒ [19-1, Cooling system, draining and filling](#) .

Coolant thermostat, removing and installing

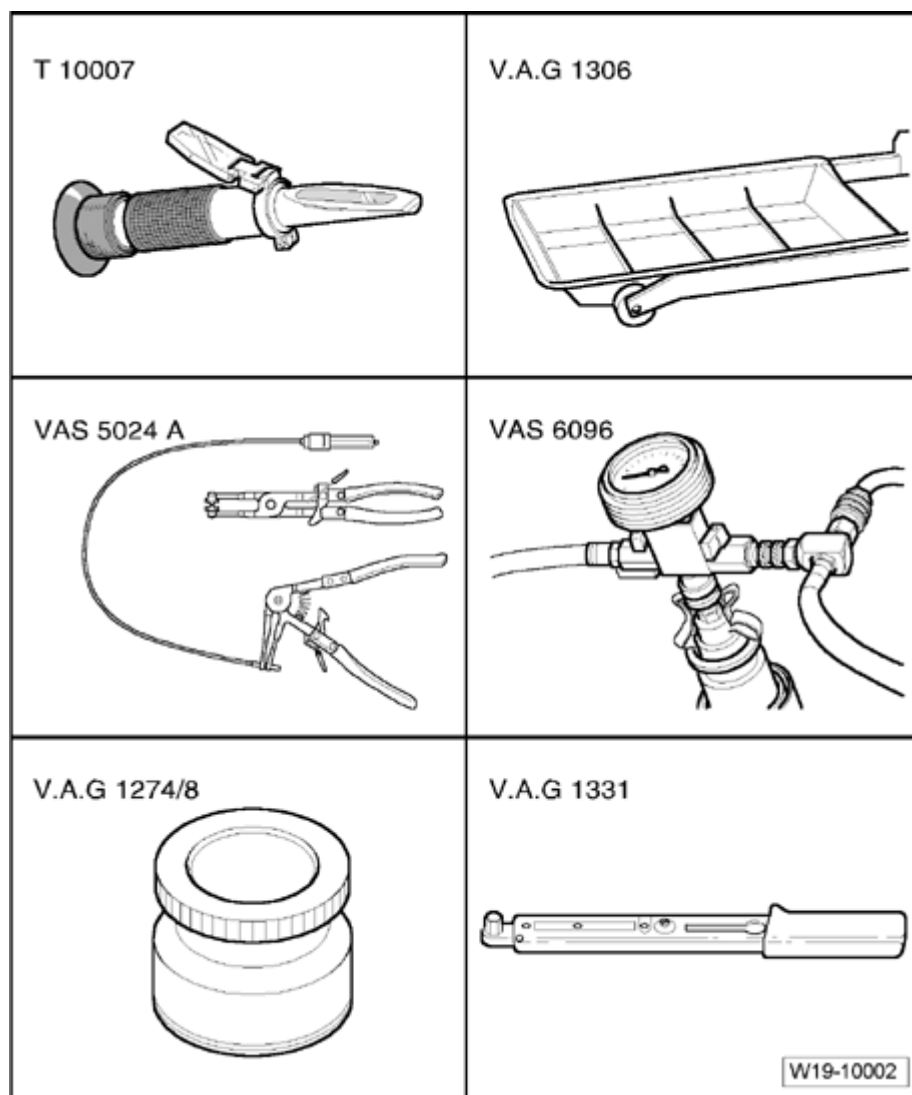

Special tools, testers and auxiliary items required

- Refractometer T10007
- Drip tray V.A.G 1306
- Pliers for spring type clips VAS 5024 A
- Cooling system charge unit VAS 6096
- Adapter V.A.G 1274/8
- Torque wrench (5 to 50 Nm) V.A.G 1331

Special tools, testers and auxiliary items required

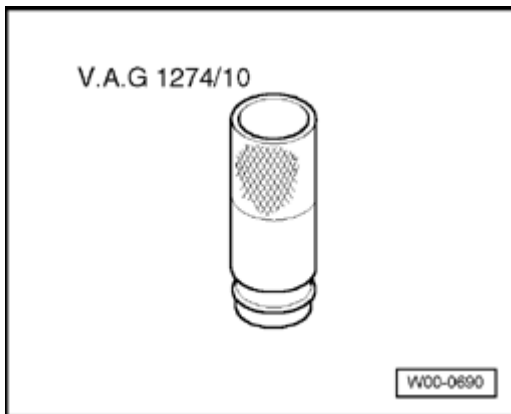

- Adapter V.A.G 1274/10

Removing

Note:

- *Always replace gaskets and seals.*

- Drain coolant ⇒ [19-1, Cooling system, draining and filling](#) .

- Disconnect coolant hose from housing.

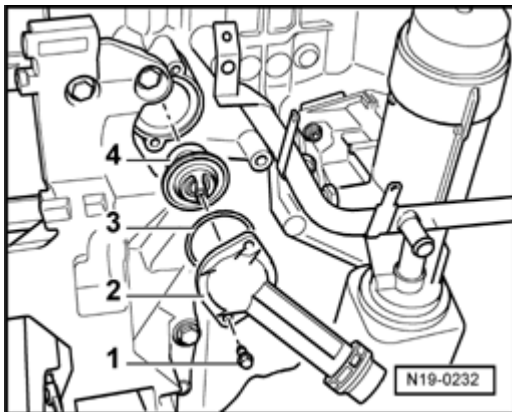

- Unscrew bolts - **1** - from housing - **2** - and remove with coolant thermostat - **4** - .

- Turn coolant thermostat - **4** - $\frac{1}{4}$ turn (90°) left and remove it from housing - **2** - .

Installing

Installation is performed in the reverse order of removal, note the following:

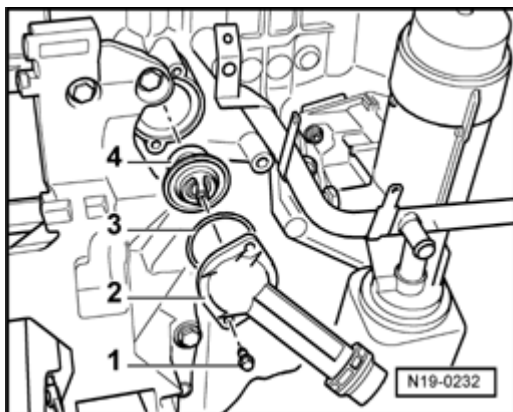

- Moisten new O-ring - **3** - with coolant and install.
- Insert coolant thermostat - **4** - into housing - **2** - and turn right $1/4$ turn (90°).

Note:

- *The clip of the thermostat must be positioned at approx. right angle.*

- Insert housing - **2** - with thermostat - **4** - into engine block.
- Tighten bolts - **1** - : Torque specification 15 Nm
- Fill with coolant \Rightarrow [19-1, Cooling system, draining and filling](#) .

Viscous fan clutch, removing and installing

Special tools, testers and auxiliary items required

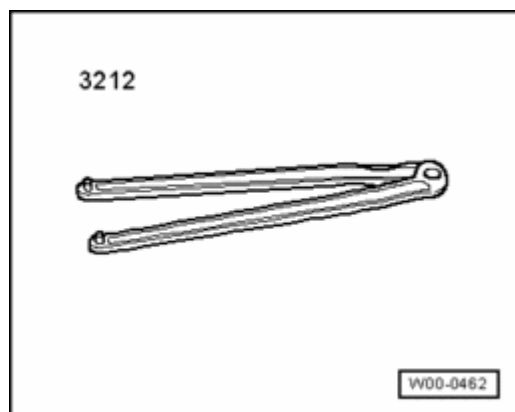

- Pin wrench 3212

Special tools, testers and auxiliary items required

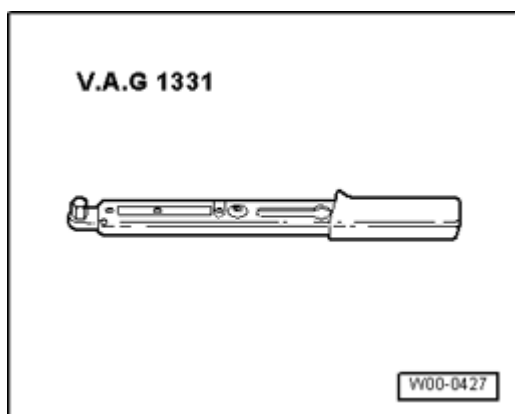

- Torque wrench (5 to 50 Nm) V.A.G 1331

Removing

- Bring lock carrier into service position.

⇒ *Repair Manual, Body Exterior, Repair Group 50, Body - front*

- Remove ribbed belt ⇒ [13-1, Ribbed belt, removing and installing](#) .

- Remove fan wheel from viscous fan clutch.

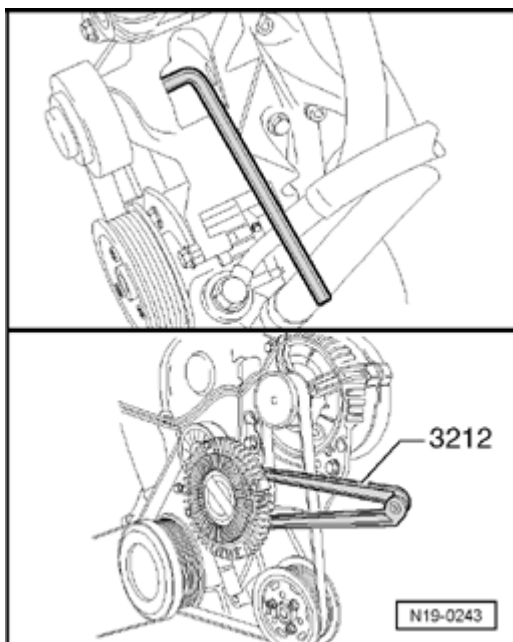

- Counterhold belt pulley for viscous fan clutch with pin wrench 3212 and unscrew from bracket with 8 mm hex socket wrench.

- Remove belt pulley from viscous fan clutch.

Installing

Installation is performed in the reverse order of removal, note the following:

- Tighten belt pulley to viscous fan clutch to 30 Nm.
- Tighten viscous fan clutch to bracket to 45 Nm.
- Tighten fan wheel to viscous fan clutch to 10 Nm.
- Install ribbed belt ⇒ [13-1, Ribbed belt, removing and installing](#) .